

The Circle Past Papers Unit 2 outcome 4

Multiple Choice Questions

Each correct answer in this section is worth two marks.

1. A circle has equation $(x - 3)^2 + (y + 4)^2 = 20$.

Find the gradient of the tangent to the circle at the point $(1, 0)$.

- A. -2
 B. $-\frac{1}{2}$
 C. $\frac{1}{2}$
 D. 2

Key	Outcome	Grade	Facility	Disc.	Calculator	Content	Source
C	2.4	C	0.43	0.77	NC	G9, G2, G5	HSN 097

The centre is $(3, -4)$.

$$m_{\text{radius}} = \frac{0 - (-4)}{1 - 3} = \frac{4}{-2} = -2.$$

So $m_{\text{tgt}} = \frac{1}{2}$ since the radius and tangent are perpendicular.

Option C

[END OF MULTIPLE CHOICE QUESTIONS]

Written Questions

- [SQA] 2. Find the equation of the tangent at the point $(3, 4)$ on the circle $x^2 + y^2 + 2x - 4y - 15 = 0$.

4

part marks	Unit	non-calc		calc		calc neut		Content Reference :		1.1
		C	A/B	C	A/B	C	A/B	Main	Additional	
4	1.1					4		1.1.1	1.1.9, 2.4.2	Source: 1996 P1 qu.4

- ¹ centre = $(-1, 2)$
- ² $m_{\text{radius}} = \frac{1}{2}$
- ³ $m_{\text{tgt}} = -2$
- ⁴ $y - 4 = -2(x - 3)$

- [SQA] 3. Find the equation of the tangent at the point (3,1) on the circle $x^2 + y^2 - 4x + 6y - 4 = 0$.

5

part marks	Unit	non-calc		calc		calc neut		Content Reference :		2.4
		C	A/B	C	A/B	C	A/B	Main	Additional	
5	2.4					5		2.4.4		Source 1991 P1 qu.8

- ¹ strat: use centre and tgt \perp radius
- ² centre = (2, -3)
- ³ $m_{\text{radius}} = 4$
- ⁴ $m_{\text{tgt}} = -\frac{1}{4}$
- ⁵ $y - 1 = -\frac{1}{4}(x - 3)$

- [SQA] 4. Find the equation of the circle which has P(-2, -1) and Q(4, 5) as the end points of a diameter.

3

part marks	Unit	non-calc		calc		calc neut		Content Reference :		2.4
		C	A/B	C	A/B	C	A/B	Main	Additional	
3	2.4					3		2.4.3		Source 1995 P1 qu.9

- ¹ (1, 2)
- ² $\sqrt{(4-1)^2 + (5-2)^2}$ or equiv.
- ³ $(x-1)^2 + (y-2)^2 = 18$ or equiv.

- [SQA] 5. The point P(2, 3) lies on the circle $(x + 1)^2 + (y - 1)^2 = 13$. Find the equation of the tangent at P.

4

Part	Marks	Level	Calc.	Content	Answer	U2 OC4
	4	C	CN	G11	$2y + 3x = 12$	2002 P1 Q1

<ul style="list-style-type: none"> •¹ ic: interpret centre from equ. of circle •² ss: know to find gradient of radius •³ ss: know to find perp. gradient •⁴ ic: state equation of tangent 	<ul style="list-style-type: none"> •¹ $C = (-1, 1)$ •² $m_{\text{rad}} = \frac{2}{3}$ •³ $m_{\text{tgt}} = -\frac{3}{2}$ •⁴ $y - 3 = -\frac{3}{2}(x - 2)$
---	---

- [SQA] 6. The line $y = -1$ is a tangent to a circle which passes through $(0, 0)$ and $(6, 0)$.
Find the equation of this circle.

6

part	marks	Unit	non-calc		calc		calc neut		Content Reference :		2.4
			C	A/B	C	A/B	C	A/B	Main	Additional	
.	6	2.4					1	5	2.4.3	0.1	Source 1996 P1 qu.20

<ul style="list-style-type: none"> •¹ sketch with point of con.P = (3,-1) •² Centre C=(3,y) •³ CO² = CP² •⁴ y = 4 •⁵ radius = 5 •⁶ (x-3)² + (y-4)² = 25 	OR	<ul style="list-style-type: none"> •¹ (x-3)² + (y-k)² = r² •² r² = k² + 9 •³ (x-3)² + (-1-k)² = r² has 'm' roots •⁴ reduce to x² - 6x + (2k+1) •⁵ k = 4 •⁶ (x-3)² + (y-4)² = 25 	OR	<ul style="list-style-type: none"> •¹ sketch with point of con.P = (3,-1) •² x² + y² + 2gx + 2fy + c = 0 •³ (0,0) ⇒ c = 0 •⁴ (6,0) ⇒ g = -3 •⁵ (3,-1) ⇒ f = -4 •⁶ x² + y² - 6x - 8y = 0
---	----	--	----	---

- [SQA] 7. Find the possible values of k for which the line $x - y = k$ is a tangent to the circle $x^2 + y^2 = 18$.

5

part	marks	Unit	non-calc		calc		calc neut		Content Reference :		2.4
			C	A/B	C	A/B	C	A/B	Main	Additional	
.	5	2.4					2	3	2.4.4		Source 1989 P1 qu.18

<ul style="list-style-type: none"> •¹ x² + (x-k)² = 18 •² 2x² - 2kx + k² - 18 = 0 •³ strat: "b² - 4ac" = 0 •⁴ (-2k)² - 4.2.(k² - 18) •⁵ k = ±6

- [SQA] 8. For what range of values of k does the equation $x^2 + y^2 + 4kx - 2ky - k - 2 = 0$ represent a circle?

5

Part	Marks	Level	Calc.	Content	Answer	U2 OC4
	5	A	NC	G9, A17	for all k	2000 P1 Q6

<ul style="list-style-type: none"> •¹ ss: know to examine radius •² pd: process •³ pd: process •⁴ ic: interpret quadratic inequation •⁵ ic: interpret quadratic inequation 	<ul style="list-style-type: none"> •¹ g = 2k, f = -k, c = -k - 2 stated or implied by •² •² r² = 5k² + k + 2 •³ (real r ⇒) 5k² + k + 2 > 0 (accept ≥) •⁴ use discr. or complete sq. or diff. •⁵ true for all k
--	---

- [SQA] 9. Explain why the equation $x^2 + y^2 + 2x + 3y + 5 = 0$ does **not** represent a circle. 2

part marks	Unit	non-calc		calc		calc neut		Content Reference :		2.4
		C	A/B	C	A/B	C	A/B	Main	Additional	
2	2.4					2		2.4.2		Source 1993 P1 qu.18

- ¹ $g^2 + f^2 - c = -1\frac{3}{4}$
- ² $r = \sqrt{-1\frac{3}{4}}$ which is not possible

- [SQA] 10. For what range of values of c does the equation $x^2 + y^2 - 6x + 4y + c = 0$ represent a circle? 3

part marks	Unit	non-calc		calc		calc neut		Content Reference :		2.4
		C	A/B	C	A/B	C	A/B	Main	Additional	
3	2.4					2	1	2.4.2		Source 1997 P1 qu.14

- ¹ $g^2 + f^2 - c > 0$
- ² $r^2 = 9 + 4 - c$
- ³ $c < 13$

- [SQA] 11. Circle P has equation $x^2 + y^2 - 8x - 10y + 9 = 0$. Circle Q has centre $(-2, -1)$ and radius $2\sqrt{2}$.
- (a) (i) Show that the radius of circle P is $4\sqrt{2}$.
 (ii) Hence show that circles P and Q touch. 4
- (b) Find the equation of the tangent to the circle Q at the point $(-4, 1)$. 3
- (c) The tangent in (b) intersects circle P in two points. Find the x -coordinates of the points of intersection, expressing your answers in the form $a \pm b\sqrt{3}$. 3

Part	Marks	Level	Calc.	Content	Answer	U2 OC4
(a)	2	C	CN	G9	proof	2001 P1 Q11
(a)	2	A/B	CN	G14		
(b)	3	C	CN	G11	$y = x + 5$	
(c)	3	C	CN	G12	$x = 2 \pm 2\sqrt{3}$	

<ul style="list-style-type: none"> •¹ ic: interpret centre of circle (P) •² ss: find radius of circle (P) •³ ss: find sum of radii •⁴ pd: compare with distance between centres •⁵ ss: find gradient of radius •⁶ ss: use $m_1 m_2 = -1$ •⁷ ic: state equation of tangent •⁸ ss: substitute linear into circle •⁹ pd: express in standard form •¹⁰ pd: solve (quadratic) equation 	<ul style="list-style-type: none"> •¹ $C_P = (4, 5)$ •² $r_P = \sqrt{16 + 25 - 9} = \sqrt{32} = 4\sqrt{2}$ •³ $r_P + r_Q = 4\sqrt{2} + 2\sqrt{2} = 6\sqrt{2}$ •⁴ $C_P C_Q = \sqrt{6^2 + 6^2} = 6\sqrt{2}$ and "so touch" •⁵ $m_r = -1$ •⁶ $m_{tgt} = +1$ •⁷ $y - 1 = 1(x + 4)$ •⁸ $x^2 + (x + 5)^2 - 8x - 10(x + 5) + 9 = 0$ •⁹ $2x^2 - 8x - 16 = 0$ •¹⁰ $x = 2 \pm 2\sqrt{3}$
--	--

[SQA] 12. (a) Find the equation of AB, the perpendicular bisector of the line joining the points P(-3,1) and Q(1,9).

(b) C is the centre of a circle passing through P and Q. Given that QC is parallel to the y-axis, determine the equation of the circle.

(c) The tangents at P and Q intersect at T.

Write down

(i) the equation of the tangent at Q

(ii) the coordinates of T.

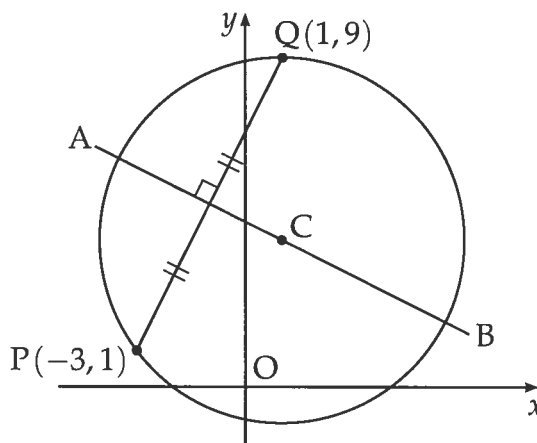

4

3

2

Part	Marks	Level	Calc.	Content	Answer	U2 OC4
(a)	4	C	CN	G7	$x + 2y = 9$	2000 P2 Q2
(b)	3	C	CN	G10	$(x - 1)^2 + (y - 4)^2 = 25$	
(c)	2	C	CN	G11, G8	(i) $y = 9$, (ii) $T(-9, 9)$	

<ul style="list-style-type: none"> •¹ ss: know to use midpoint •² pd: process gradient of PQ •³ ss: know how to find perp. gradient •⁴ ic: state equ. of line •⁵ ic: interpret "parallel to y-axis" •⁶ pd: process radius •⁷ ic: state equ. of circle •⁸ ic: interpret diagram •⁹ ss: know to use equ. of AB 	<ul style="list-style-type: none"> •¹ midpoint = (-1, 5) •² $m_{PQ} = \frac{9-1}{1-(-1)}$ •³ $m_{\perp} = -\frac{1}{2}$ •⁴ $y - 5 = -\frac{1}{2}(x - (-1))$ •⁵ $y_C = 4$ stated or implied by •⁷ •⁶ radius = 5 or equiv. stated or implied by •⁷ •⁷ $(x - 1)^2 + (y - 4)^2 = 25$ •⁸ $y = 9$ •⁹ $T = (-9, 9)$
--	---

- [SQA] 13. Find the equation of the circle with centre $(-3, 4)$ and passing through the origin.

2

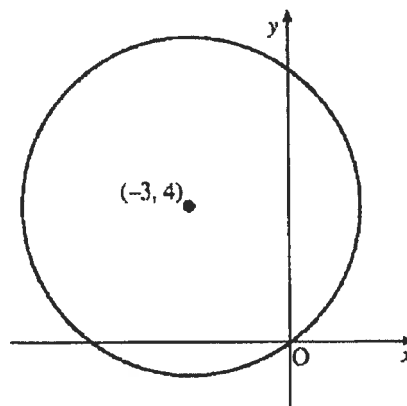

part marks	Unit	non-calc		calc		calc neut		Content Reference :		2.4
		C	A/B	C	A/B	C	A/B	Main	Additional	
2	2.4					2		2.4.3		Source 1999 P1 qu.4

•¹ $r^2 = 25$ stated or implied by •².
 •² $(x+3)^2 + (y-4)^2 = 25$

- [SQA] 14. The circle shown has equation $(x-3)^2 + (y+2)^2 = 25$. Find the equation of the tangent at the point $(6, 2)$.

4

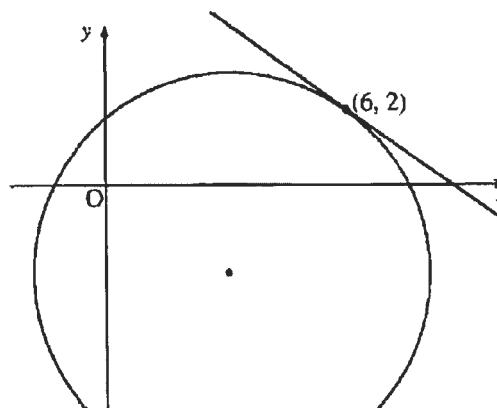

part marks	Unit	non-calc		calc		calc neut		Content Reference :		2.4
		C	A/B	C	A/B	C	A/B	Main	Additional	
4	2.4					4		2.4.4		Source 1998 P1 qu.4

•¹ Centre = $(3, -2)$
 •² $m_{rad} = \frac{4}{3}$
 •³ $m_{tg} = -\frac{3}{4}$
 •⁴ $y - 2 = -\frac{3}{4}(x - 6)$

- [SQA] 15. The straight line $y = x$ cuts the circle $x^2 + y^2 - 6x - 2y - 24 = 0$ at A and B.
 (a) Find the coordinates of A and B.
 (b) Find the equation of the circle which has AB as diameter.

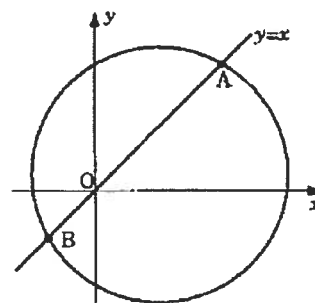

3
3

part	marks	Unit	non-calc		calc		calc neut		Content Reference :		2.4
			C	A/B	C	A/B	C	A/B	Main	Additional	
(a)	3	2.4					3		2.4.4		Source
(b)	3	2.4					3		2.4.3		1994 P1 qu.8

• ¹	$x^2 + y^2 - 6x - 2y - 24 = 0$	OR	• ⁴	centre is (2, 2)
• ²	$(x + 2)(x - 6) = 0$		• ⁵	radius is $\sqrt{32}$ or equivalent
• ³	(-2, -2) and (6, 6)		• ⁶	$(x - 2)^2 + (y - 2)^2 = 32$

- [SQA] 16. Diagram 1 shows a circle with equation $x^2 + y^2 + 10x - 2y - 14 = 0$ and a straight line, l_1 , with equation $y = 2x + 1$. The line intersects the circle at A and B.

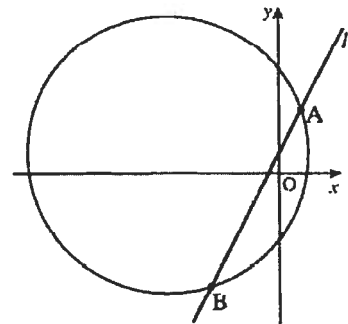

Diagram 1

- (a) Find the coordinates of the points A and B. (5)

- (b) Diagram 2 shows a second line, l_2 , which passes through the centre of the circle, C, and is at right angles to line l_1 .

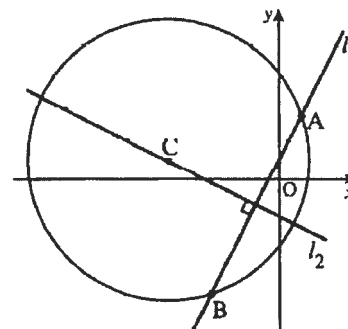

Diagram 2

- (i) Write down the coordinates of C. (1)
 (ii) Find the equation of the line l_2 . (3)

part	marks	Unit	non-calc		calc		calc neut		Content Reference :		2.4
			C	A/B	C	A/B	C	A/B	Main	Additional	
(a)	5	2.4					5		2.4.4		Source 1997 Paper 2 Qu.1
(b)i	1	2.4					1		2.4.2		
(b)ii	3	1.1					3		1.1.10 1.1.7		

(a)	• ¹	know to substitute
	• ²	correct substitution
	• ³	a "quadratic" = 0
	• ⁴	$x = -3, 1$
	• ⁵	$y = -5, 3$
(b)	• ⁶	$m_{\text{diameter}} = 2$
	• ⁷	$m_{\text{perpendicular}} = -\frac{1}{2}$
	• ⁸	centre = $(-1, -1)$
	• ⁹	equation: $y + 1 = -\frac{1}{2}(x + 1)$

- [SQA] 17. AB is a tangent at B to the circle with centre C and equation $(x-2)^2 + (y-2)^2 = 25$.
The point A has co-ordinates (10, 8).
Find the area of triangle ABC.

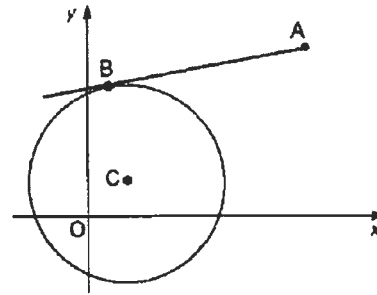

5

part marks	Unit	non-calc		calc		calc neut		Content Reference :		2.4
		C	A/B	C	A/B	C	A/B	Main	Additional	
5	2.4					5		2.4.1	1.1.2, 0.1	Source 1992 P1 qu.16

- ¹ strat: i.e find AC then AB
- ² centre = (2, 2) and radius = 5
- ³ AC = 10
- ⁴ AB = $\sqrt{75}$ units
- ⁵ area = $\frac{25}{2}\sqrt{3}$ square units

- [SQA] 18. The circle shown in the diagram has equation $(x-1)^2 + (y-1)^2 = 5$.
Tangents are drawn at the points (3, 2) and (2, -1).
Write down the coordinates of the centre of the circle and hence show that the tangents are perpendicular to each other.

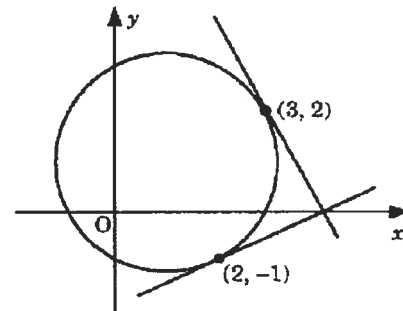

4

part marks	Unit	non-calc		calc		calc neut		Content Reference :		2.4
		C	A/B	C	A/B	C	A/B	Main	Additional	
4	2.4					4		2.4.1	1.1.9	Source 1994 P1 qu.5

- | | | |
|---|----|---|
| <ul style="list-style-type: none"> •¹ centre = (1, 1) •² $m_{radii} = \frac{1}{2}, -2$ •³ $m_{tgts} = -2, \frac{1}{2}$ •⁴ $-2 \times \frac{1}{2} = -1 \Rightarrow$ tgts are \perp | OR | <ul style="list-style-type: none"> •¹ centre = (1, 1) •² $r = \sqrt{5}, d = \sqrt{10}$ •³ Show $\widehat{ACB} = 90^\circ$ •⁴ State tangents \perp to radii |
|---|----|---|

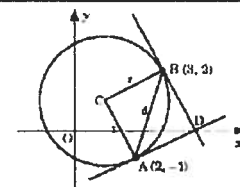

- [SQA] 19. (a) The diagram shows a circle, centre P , with equation $x^2 + y^2 + 6x + 4y + 8 = 0$.
Find the equation of the tangent at the point $A(-1, -1)$ on the circle.

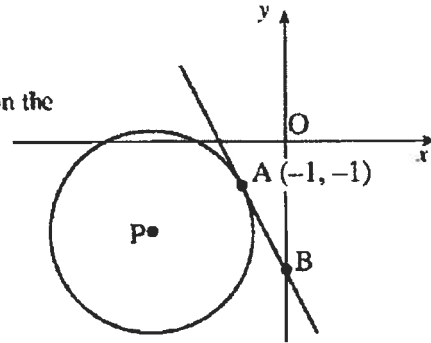

- (b) The tangent crosses the y -axis at B .
Find the coordinates of B .

- (c) Another circle, centre P , is drawn passing through B . The tangent at A meets the second circle at the point C , as shown in the diagram.
Write down the coordinates of C .

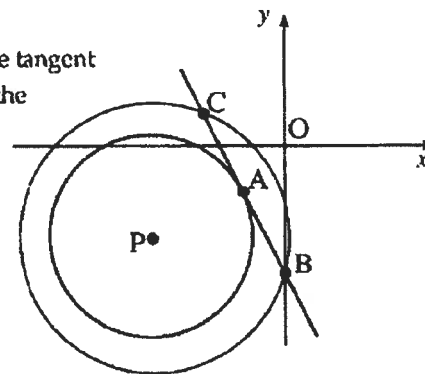

- (d) Find the equation of the circle with BC as diameter.

part	marks	Unit	non-calc		calc		calc neut		Content Reference :		2.4
			C	A/B	C	A/B	C	A/B	Main	Additional	
(a)	4	2.4					4		2.4.2	1.1.9	Source 1999 Paper 2 Qu. 2
(b)	1	0.1					1		0.1		
(c)	1	0.1					1		0.1		
(d)	2	2.4					2		2.4.4		

(a)	• ¹	centre = $(-3, -2)$
	• ²	$m_{rad} = \frac{1}{2}$
	• ³	$m_{tgt} = -2$
	• ⁴	$y - (-1) = -2(x - (-1))$
(b)	• ⁵	$B = (0, -3)$
(c)	• ⁶	$C = (-2, 1)$
(d)	• ⁷	$r^2 = 5$
	• ⁸	$(x+1)^2 + (y+1)^2 = 5$

- [SQA] 20. In an experiment with a ripple tank, a series of concentric circles with centre $C(4, -1)$ is formed as shown in the diagram.
- The line l with equation $y = 2x + 6$ represents a barrier placed in the tank. The largest complete circle touches the barrier at the point T .

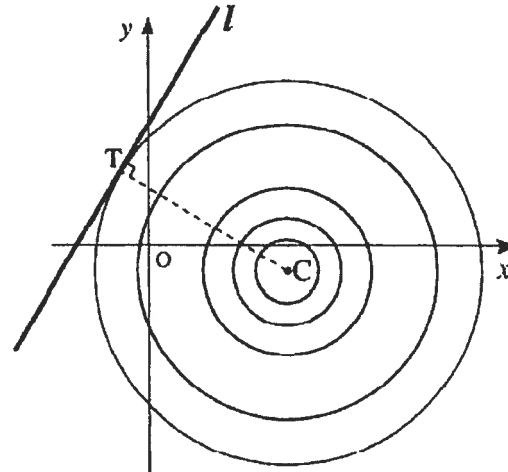

- (a) Find the equation of the radius CT . (3)
- (b) Find the equation of the largest complete circle. (5)

part	marks	Unit	non-calc		calc		calc neut		Content Reference :		2.4
			C	A/B	C	A/B	C	A/B	Main	Additional	
(a)	3	1.1					3		1.1.9,	1.1.7	Source 1993 Paper 2 Qu.3
(b)	5	2.4					5		2.4.3		

- (a)
- ¹ $m_l = 2$
 - ² $m_r = -\frac{1}{2}$
 - ³ $y + 1 = -\frac{1}{2}(x - 4)$
- (b)
- ⁴ $(x - 4)^2 + (y + 1)^2 = r^2$
 - ⁵ $(x - 4)^2 + (2x + 7)^2 = r^2$
 - ⁶ $5x^2 + 20x + (65 - r^2) = 0$
 - ⁷ $\Delta = 400 - 4 \times 5(65 - r^2) = 0$
 - ⁸ $r^2 = 45$

- [SQA] 21. (a) In the diagram, A is the point $(-1, 1)$, B is $(3, 3)$ and C is $(6, 2)$. The perpendicular bisector of AB has equation $y + 2x = 4$. Find the equation of the perpendicular bisector of BC. (4)

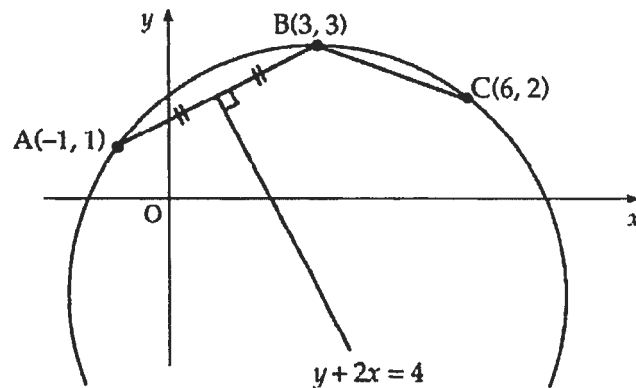

- (b) Find the centre and the equation of the circle which passes through A, B and C. (6)

part	marks	Unit	non-calc		calc		calc neut		Content Reference :		2.4
			C	A/B	C	A/B	C	A/B	Main	Additional	
(a)	4	1.1					4		1.1.9,	1.1.7	Source 1991 Paper 2 Qu. 2
(b)	6	2.4					6		2.4.3,	1.1.2	

- (a)
- ¹ $m_{BC} = -\frac{1}{3}$
 - ² $m_{\perp} = 3$
 - ³ $\text{midpoint}_{BC} = \left(\frac{9}{2}, \frac{5}{2}\right)$
 - ⁴ $y - \frac{5}{2} = 3\left(x - \frac{9}{2}\right)$
- (b)
- ⁵ $y - 3x = -11$
 - ⁶ perp. bisector passes thr' centre stated explicitly
 - ⁷ using $y - 3x = -11$ and $y + 2x = 4$
 - ⁸ $(3, -2)$
 - ⁹ $r^2 = 25$
 - ¹⁰ $(x - 3)^2 + (y + 2)^2 = 25$

- [SQA] 22. Two identical circles touch at the point P (9, 3) as shown in the diagram. One of the circles has equation $x^2 + y^2 - 10x - 4y + 12 = 0$.

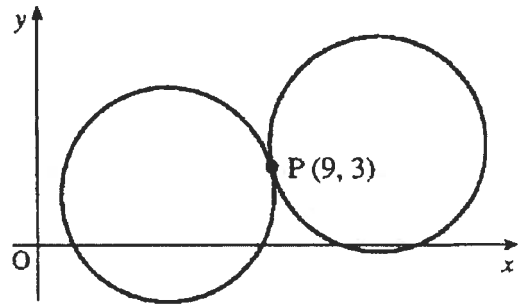

Find the equation of the other circle.

5

part marks	Unit	non-calc		calc		calc neut		Content Reference :		2.4
		C	A/B	C	A/B	C	A/B	Main	Additional	
5	2.4					5		2.4.2	(3.1.6)	Source 1997 P1 qu.12

<ul style="list-style-type: none"> •¹ use P as midpoint of C_1C_2 •² $C_1 = (5, 2)$ •³ $C_2 = (13, 4)$ •⁴ radius = $\sqrt{17}$ •⁵ $(x - 13)^2 + (y - 4)^2 = 17$
--

- [SQA] 23. This diagram shows a computer-generated display of a game of noughts and crosses. Relative to the coordinate axes which have been added to the display, the "nought" at A is represented by a circle with equation $(x - 2)^2 + (y - 2)^2 = 4$.

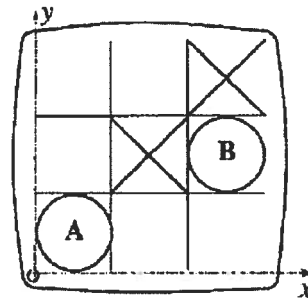

- (a) Find the centre of the circle at B.
 (b) Find the equation of the circle at B.

3
1

part marks	Unit	non-calc		calc		calc neut		Content Reference :		2.4
		C	A/B	C	A/B	C	A/B	Main	Additional	
(a)	3	2.4				3		2.4.1		Source
(b)	1	2.4				1		2.4.3		1993 P1 qu.5

<ul style="list-style-type: none"> •¹ radius_A = 2 •² centre_A = (2, 2) •³ centre_B = (10, 6) •⁴ $(x - 10)^2 + (y - 6)^2 = 4$
--

[SQA] 24.

A bakery firm makes gingerbread men each 14cm high with a circular "head" and "body".

The equation of the "body" is $x^2 + y^2 + 10x - 12y + 45 = 0$ and the line of centres is parallel to the y -axis. Find the equation of the "head".

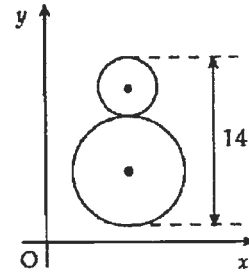

5

part marks	Unit	non-calc		calc		calc neut		Content Reference :		2.4
		C	A/B	C	A/B	C	A/B	Main	Additional	
5	2.4					5		2.4.2	2.4.3	Source 1990 P1 qu.7
<ul style="list-style-type: none"> •¹ centre of body = (5,6) •² radius of body = 4 •³ radius of head = 3 •⁴ centre of head = (5,13) •⁵ $(x - 5)^2 + (y - 13)^2 = 9$ 										

- [SQA] 25. When newspapers were printed by lithograph, the newsprint had to run over three rollers, illustrated in the diagram by three circles. The centres A, B and C of the three circles are collinear.

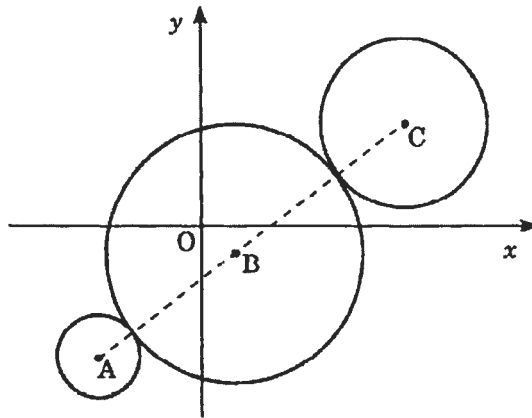

The equations of the circumferences of the outer circles are

$$(x + 12)^2 + (y + 15)^2 = 25 \text{ and } (x - 24)^2 + (y - 12)^2 = 100.$$

Find the equation of the central circle.

(8)

part marks	Unit	non-calc		calc		calc neut		Content Reference :		3.1
		C	A/B	C	A/B	C	A/B	Main	Additional	
- 8	3.1					8		2.4.1, 2.4.3, 3.1.6	Source 1995 Paper 2 Qu.8	

- (-)
- ¹ $(-12, -15)$ and $(24, 12)$
 - ² radii are 5 and 10
 - ³ $AC = 45$
 - ⁴ radius = 15
 - ⁵ B divides AC in ratio 4:5
 - ⁶ $\vec{OB} = \frac{1}{9} [4\vec{OC} + 5\vec{OA}]$ stated or implied
 - ⁷ $\vec{OB} = \frac{1}{9} \left[4 \begin{pmatrix} 24 \\ 12 \end{pmatrix} + 5 \begin{pmatrix} -12 \\ -15 \end{pmatrix} \right]$
 - ⁸ $(x - 4)^2 + (y + 3)^2 = 15^2$

- [SQA] 26. The shape shown in the diagram is composed of 3 semicircles with centres A, B and C which lie on a straight line.

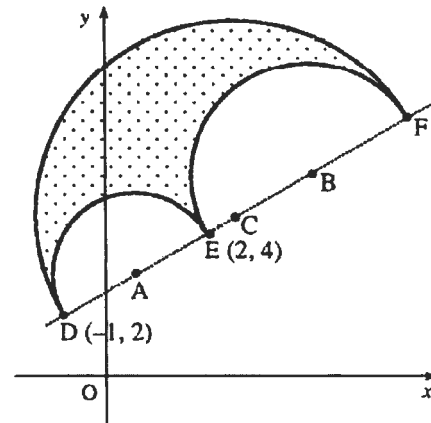

DE is a diameter of one of the semicircles. The coordinates of D and E are $(-1, 2)$ and $(2, 4)$.

- (a) Find the equation of the circle with centre A and diameter DE. (3)

The circle with centre B and diameter EF has equation $x^2 + y^2 - 16x - 16y + 76 = 0$.

- (b) (i) Write down the coordinates of B. (3)
 (ii) Determine the coordinates of F and C. (3)
- (c) In the diagram the perimeter of the shape is represented by the thick black line. Show that the perimeter is $5\pi\sqrt{13}$ units. (3)

part	marks	Unit	non-calc		calc		calc neut		Content Reference :		2.4
			C	A/B	C	A/B	C	A/B	Main	Additional	
(a)	3	2.4					3		2.4.3		Source 1998 Paper 2 Qu. 6
(b)	3	2.4					3		2.4.2 & 3.1.6		
(c)	3	0.1					3		0.1		

(a)	<ul style="list-style-type: none"> •¹ $A = (\frac{1}{2}, 3)$ •² $r^2 = \frac{9}{4} + 1$ or $d^2 = 13$ •³ $(x - \frac{1}{2})^2 + (y - 3)^2 = \frac{13}{4}$ or $x^2 + y^2 - x - 6y + 6 = 0$
(b)	<ul style="list-style-type: none"> •⁴ $B (8, 8)$ •⁵ $F (14, 12)$ •⁶ $C (\frac{13}{2}, 7)$
(c)	<ul style="list-style-type: none"> •⁷ $\frac{1}{2}\pi DF + \frac{1}{2}\pi DE + \frac{1}{2}\pi EF$ •⁸ $\frac{1}{2}\pi DF = \frac{5}{2}\pi\sqrt{13}$ OR $\frac{1}{2}\pi EF = 2\pi\sqrt{13}$ •⁹ $\frac{5}{2}\pi\sqrt{13} + \frac{1}{2}\pi\sqrt{13} + 2\pi\sqrt{13}$

[SQA] 27.

A spherical hot-air balloon has radius 30 feet. Cables join the balloon to the gondola which is cylindrical with diameter 6 feet and height 4 feet. The top of the gondola is 16 feet below the bottom of the balloon.

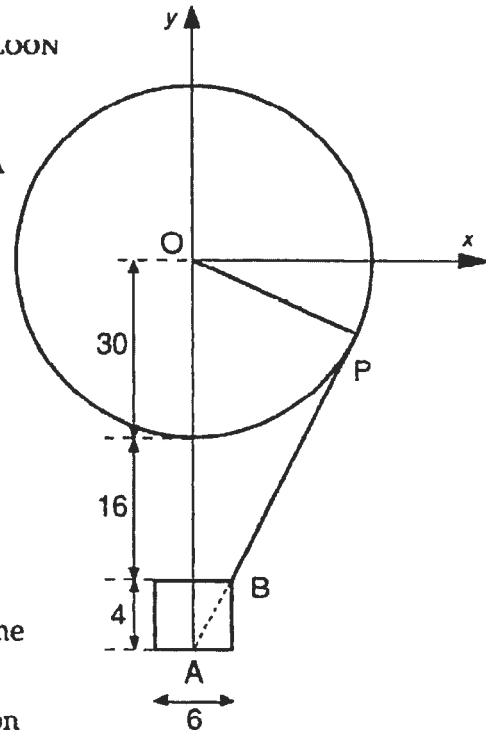

Co-ordinate axes are chosen as shown in the diagram. One of the cables is represented by PB and PBA is a straight line.

- (a) Find the equation of the cable PB. (3)
- (b) State the equation of the circle representing the balloon. (1)
- (c) Prove that this cable is a tangent to the balloon and find the co-ordinates of the point P. (5)

part	marks	Unit	non-calc		calc		calc neut		Content Reference :		2.4
			C	A/B	C	A/B	C	A/B	Main	Additional	
(a)	3	1.1					3		1.1.1,	1.1.7	Source 1992 Paper 2 Qu.9
(b)	1	2.4					1		2.4.3		
(c)	5	2.4					2	3	2.4.4		

(a)	• ¹	Strategy: know to find m
	• ²	$m = \frac{4}{3}$
	• ³	$y + 46 = \frac{4}{3}(x - 3)$
(b)	• ⁴	$x^2 + y^2 = 900$ or equivalent
(c)	• ⁵	Strategy: know to substitute
	• ⁶	$x^2 + \left(\frac{4}{3}x - 50\right)^2 = 900$
	• ⁷	$(x - 24)^2$ or evaluate the discriminant
	• ⁸	communication relating to tangency
	• ⁹	$(24, -18)$

[SQA] 28.

A sports club awards trophies in the form of paperweights bearing the club crest. Diagram 1 shows the front view of one of these paperweights. Each is made from two different types of glass. The two circles are concentric and the base line is a tangent to the inner circle.

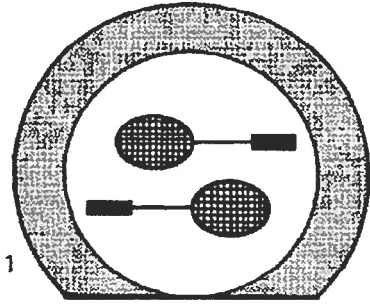

Diagram 1

- (a) Relative to x, y coordinate axes, the equation of the outer circle is $x^2 + y^2 - 8x + 2y - 19 = 0$ and the equation of the base line is $y = -6$.

Show that the equation of the inner circle is $x^2 + y^2 - 8x + 2y - 8 = 0$.

(4)

- (b) An alternative form of the paperweight is made by cutting off a piece of glass from the original design along a second line with equation $3x - 4y + 9 = 0$ as shown in diagram 2.

Show that this line is a tangent to the inner circle and state the coordinates of the point of contact.

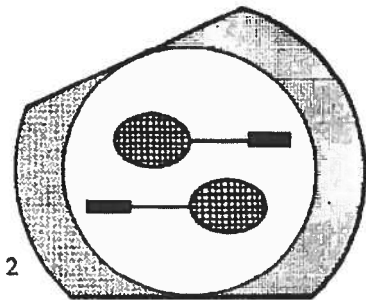

Diagram 2

(7)

part	marks	Unit	non-calc		calc		calc neut		Content Reference :		2.4
			C	A/B	C	A/B	C	A/B	Main	Additional	
(a)	4	2.4					4		2.4.3		Source 1990 Paper 2 Qu. 8
(b)	7	2.4					3	4	2.4.4		

(a)	<ul style="list-style-type: none"> •¹ centre = $(4, -1)$ •² inner radius = 5 •³ $(x - 4)^2 + (y + 1)^2 = 25$ •⁴ completing argument
(b)	<ul style="list-style-type: none"> •⁵ e.g. $x = \frac{4}{3}y - 3$ •⁶ $(\frac{4}{3}y - 3)^2 + y^2 - 8(\frac{4}{3}y - 3) + 2y - 8 = 0$ •⁷ $\frac{16}{9}y^2 - 8y + 9 + y^2 - \frac{32}{3}y + 24 + 2y - 8$ •⁸ $y^2 - 6y + 9 = 0$ •⁹ e.g. $(y - 3)(y - 3) = 0$ •¹⁰ equal roots \Rightarrow line is a tangent •¹¹ $(1, 3)$

- [SQA] 29. A penny-farthing bicycle on display in a museum is supported by a stand at points A and C. A and C lie on the front wheel.

With coordinate axes as shown and 1 unit = 5cm, the equation of the rear wheel (the small wheel) is

$$x^2 + y^2 - 6y = 0$$

and the equation of the front wheel is

$$x^2 + y^2 - 28x - 20y + 196 = 0.$$

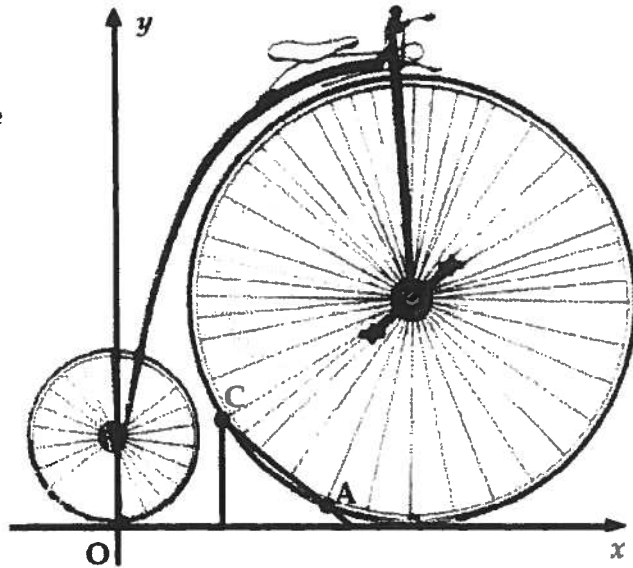

- (a) (i) Find the distance between the centres of the two wheels.
 (ii) Hence calculate the clearance, i.e. the smallest gap, between the front and rear wheels. Give your answer to the nearest millimetre. (8)
- (b) B(7,3) is half-way between A and C, and P is the centre of the front wheel.
 (i) Find the gradient of PB.
 (ii) Hence find the equation of AC and the coordinates of A and C. (8)

part	marks	Unit	non-calc		calc		calc neut		Content Reference :		2.4 Source 1994 Paper 2 Qu.4
			C	A/B	C	A/B	C	A/B	Main	Additional	
(a)	8	2.4			8				2.4.2,	1.1.2	
(b)	8	1.1			8				1.1.1,	1.1.9, 2.4.4	

- (a) •¹ centre (0, 3)
 •² centre (14, 10)
 •³ distance between centres = $\sqrt{245}$
 •⁴ radius = 3
 •⁵ radius = 10
 •⁶ strategy (clearance = distance between centres minus sum of radii)
 •⁷ $\sqrt{245} - 13$
 •⁸ 133 mm or equivalent

- (b) •⁹ $m_{PB} = 1$
 •¹⁰ $m_{AC} = -1$
 •¹¹ $y - 3 = -(x - 7)$ for AC
 •¹² strategy: substitute
 •¹³ substituting correctly
 •¹⁴ eg $2x^2 - 28x + 96 = 0$
 •¹⁵ $x = 6, 8$ (or $y = 2, 4$)
 •¹⁶ (6, 4) and (8, 2)

[END OF WRITTEN QUESTIONS]